

## Simple RIII + Two 3x SuperMo Hitachi SK-HD1500-S2 and Six HD cameras with Two replay workplaces

Replay configuration with two independent workplaces. First WP - Two Super Motion cameras in 3x mode, Second WP - 6 HD cameras (662).  
 Each SuperMo camera - three HD SDI connections: Link-A, Link-B, Link-C. DCT-based I-frame codec.  
 SDI Output 1 (3) is used for Program1 (2). SDI Output 2 (4) is used for Preview 1 (2).  
 Graphics Port 1 (2) - uses MultiSkin for displaying Main Interface (MI) or Multiviewer (MV).

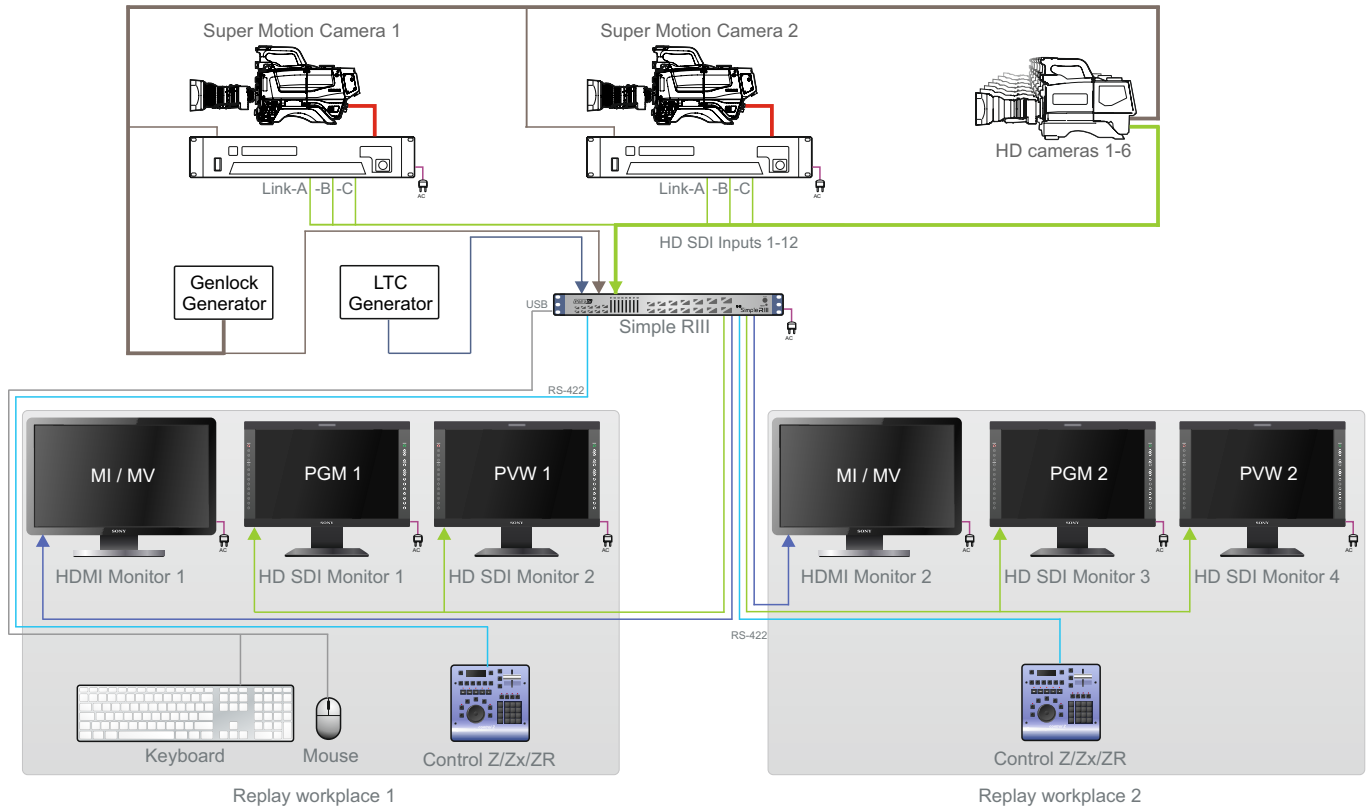

# Simple RIII + Two 3x SuperMo Hitachi SK-HD1500-S2 and Six HD cameras with Two replay workplaces

Connection diagram

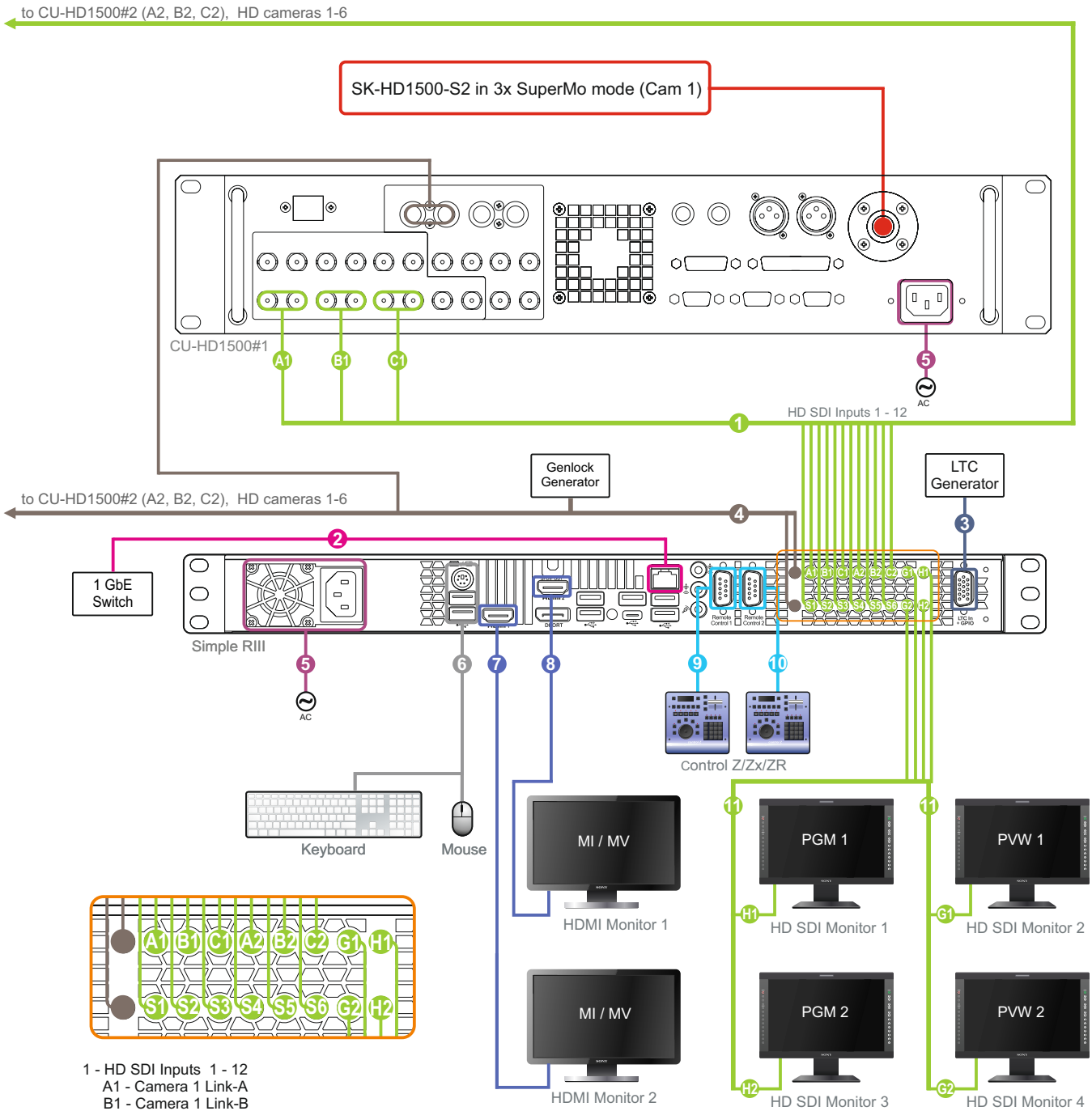

- 1 - HD SDI Inputs 1 - 12
- A1 - Camera 1 Link-A
- B1 - Camera 1 Link-B
- C1 - Camera 1 Link-C
- A2 - Camera 2 Link-A
- B2 - Camera 2 Link-B
- C2 - Camera 2 Link-C
- S1 - HD camera 1
- S2 - HD camera 2
- S3 - HD camera 3
- S4 - HD camera 4
- S5 - HD camera 5
- S6 - HD camera 6
- 2 - 1 GbE
- 3 - LTC Input
- 4 - Reference Input
- 5 - AC110/220 V 60/50Hz
- 6 - Keyboard and Mouse
- 7 - HDMI 1920 x 1080 Main Interface / Multiviewer Interface (Replay workplace 2)
- 8 - HDMI 1920 x 1080 Main Interface / Multiviewer Interface (Replay workplace 1)
- 9 - Control Z/Zx/ZR Remote Control (Replay workplace 1)
- 10 - Control Z/Zx/ZR Remote Control (Replay workplace 2)
- 11 - HD SDI Outputs
- H1 - PGM 1
- G1 - PVW 1
- H2 - PGM 2
- G2 - PVW 2

